

Transmission & Bearing Corp.

Technical Notes by Dr. Mel November 2007

What should be done to reduce the sensitivity of the LP Turbine rotor vibrations to changes in condenser back-pressure and condensate temperature?

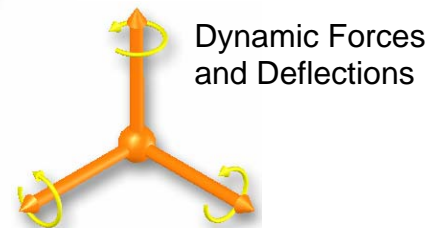
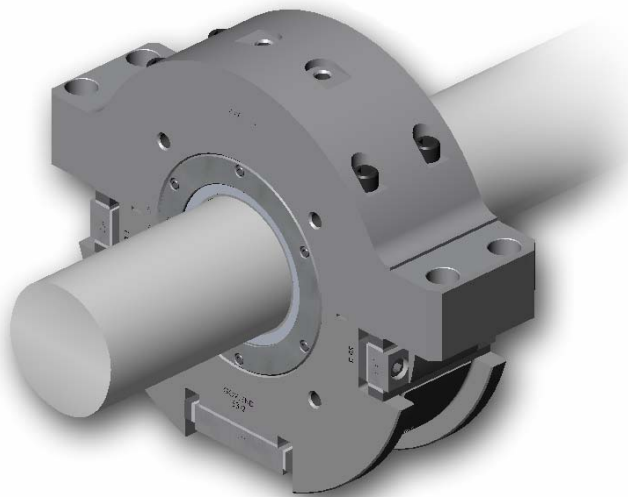

P.O. Box 454
212 Welsh Pool Rd.
Lionville, PA 19353

Tel: 610-363-8570
Fax: 610-524-6326

info@turboresarch.com
www.turboresarch.com

TRI has been asked by a number of parties about the correlations between:

- (a) Changes in LP Turbine rotor vibrations and changes in condenser back-pressure
- (b) Changes in LP turbine rotor vibrations and changes in condensate temperature.

Then the question becomes “What should be done to **reduce the sensitivity** of the LP Turbine rotor vibrations to these changes in back-pressure and temperature”? The purpose of this Tech Note is to address both of these correlations and to provide recommendations to reduce the rotor vibration sensitivity and bearing damage.

Technical Notes by Dr. Mel, November 2007

How changes in turbine back-pressure cause changes in LP Turbine rotor vibrations

There can be, and usually is, a correlation between LP Turbine back-pressure and elevation of the cone-shaped support structures for the bearings in the LP turbine hoods.

In a multi-bearing machine, dropping the elevation of one bearing shifts the loading on several bearings in both directions along the shaft line. The two adjacent bearings will pick up loading, but other bearings are affected, carrying slightly less or more load. The load shift for the various pairs of adjacent bearings of LP Turbine Bearings (4,5), (6,7), and, if they exist, Bearings (8,9), may be on the order of 1000 to 4000 lbs per mil (0.001 inches) of elevation change between each pair of adjacent bearings.

A change of loading on a bearing changes the film stiffness of that bearing: Increasing the loading on a bearing increases the stiffness, and vice versa. Changing the stiffness of the bearing film of a turbine shaft can change the effective critical speed, often not much, but in the extreme, the critical speed can actually pass through the operating speed. Furthermore, almost all rotors in service are unbalanced to some degree. If a critical speed is near the operating speed and that critical speed changes, the vibratory response (amplitude and angle) at the operating speed due to the existing unbalance distribution usually changes.

In order to understand the actual degree of change of 1X, or synchronous, vibration in a given situation, it is helpful to plot the vibratory response on a polar plot, including the slow roll data point and the roll up data for each vibration probe of the machine. The most reliable data for understanding what is occurring at each bearing in a GE machine is the "left side" data, even though the "right

side" is usually the side with the larger amplitude. For a counter-clockwise rotating machine (GE), the left side is what is called the "hard side" because the thinnest film location is approximately directly in line with this probe on the lower right of the journal, and 1 mil of motion in the direction parallel to the left side probe typically represents greater vibratory force on the bearing than 1 mil of motion measured on the right side probe. The right side is the "soft side" because the journal can slide along the thin film zone, which is why the vibrations on this side are usually larger, but usually less important than the vibrations measured on the left (hard) side.

Typically, if the overall vibration is substantially more than the 1X vibration, then the remaining vibration components are generally sub-synchronous, that is, the frequency of these vibration components is below running frequency. If there are sub-synchronous vibration components of any significant amplitude, then it is very important to note this observation. A small amount of sub-synchronous vibration usually is not a problem, but if it appears that the amplitude of the sub-synchronous component could jump to large amplitude motion, the situation should be evaluated for further action. If the unit has experienced large amplitude sub-synchronous vibratory motion in the past, then it should be evaluated for remedial action, which TRI can offer in various forms.

There are typically two ways to support condensers. For reference, older condensers were fixed to, that is, hung from, the turbine deck and they had spring supports underneath the condenser. In this case, no flexible seal was necessary at the LP Turbine hood at the turbine deck. In the older units of this design, it was absolutely critical to have the condenser filled with the proper amount of water when cold alignments of the turbine-generator were made. Too much water in the condenser, and the turbine deck would be pulled down

too far, and the alignment would not be right. Not enough water, and the turbine deck would not be pulled down enough, and the alignment would not be right.

In the 1950s, a newer design technique for supporting condensers began, in which the condensers are supported rigidly underneath from the basement, and have a flexible sealing connection (dog bone) around the top of the condenser to the LP turbine hood at the turbine deck. In this design, when a vacuum is drawn in the condenser, the entire LP Turbine hood is pulled down, as if a weight equivalent to (14.7 psia - the actual condenser pressure in psia) times the projected area of the condenser connection to the LP Turbine (sq inches) is loaded evenly on top of the LP Turbine hood. The turbine hood and surrounding foundation drop accordingly. For an LP Turbine, the reinforced concrete (or fabricated steel) support structure must carry the LP Turbine hood, the LP Turbine rotor, and the entire vacuum loading. In addition, the ends of the turbine hood are pushed inward, and this causes a rotation of the cone structures that support the LP turbine rotors. The stiffnesses of the internal support structural elements (struts, gussets, and the like) within each hood affect how the bearing elevation and bearing rotation change as a result of changes of the forces acting on the hood due to the changes in vacuum.

The vertical component of the change in vacuum loading in the present case is calculated as follows: When the back-pressure in the condenser is on the order of 1.4 in Hg, which corresponds to 0.7 psia, the total vacuum loading on the foundation is (14.7 - 0.7 = 14 psi) acting over the entire area of the LP Turbine shell. If each LP Turbine shell is 20 ft x 20 ft, this is 400 sq ft or 57,600 sq inches, the total force downwards is 806,000 lbf. This downward force will cause the elevation of the entire LP Turbine structure to drop. If the overall stiffness of the LP hood support structure is approximately 100 million lbf/inch, then the

14 psi pressure will cause the turbine deck to drop by 0.008 inches (8 mils).

Dropping the back-pressure from 1.4 inches Hg (0.7 psia) to 0.8 inches Hg (0.4 psia) increases the downward pressure on the Hood by 0.3 psi, which corresponds to another 17,280 lbf downward loading. This 0.3 psi change of loading would drop the turbine deck by an additional 0.00017 inches (0.17 mils).

Each of the bearings of an LP Turbine is in a structure called a cone. It is, in effect, a tunnel that extends out into the LP Hood. There are usually two of these cone structures per hood. These cone/tunnel structures are designed so that the bearings are located closer to the center of the LP Turbine rotors, thereby reducing the bearing spans of the LP Turbine rotors. When vacuum is drawn, the hood changes shape and each cone/tunnel structure rotates.

How changes in condensate temperature cause changes in LP Turbine rotor vibrations

There can be, and usually is, a correlation between the LP Turbine condensate temperature and the elevation of the cone support structures for the bearings in the LP Turbine hoods. A change of temperature can cause a significant change in the shape of a large steel structure, such as an LP hood. For instance, a 10 degree F change in a steel bar that is 16 inches long will change the length by 0.001 inches. If a steel structure that is 48 inches in length is subjected to a temperature change of 30 degrees (105 – 75) deg F, it will change length by 0.009 inches.

Experience over many years indicates that it is very difficult to know how the bearings and the shaft line are going to respond to a change in vacuum (back-pressure) and/or to a change in temperature of the LP hood before a machine and its mounting structure are built. Similar units react in different

ways. The locations of gussets in an LP hood, how the hood is supported by the foundation, and how the foundation is built (concrete or steel) affect how the hood will distort elastically, and hence, how the bearing elevations will change with a change in vacuum and/or condensate temperature.

In the US, usually the foundations are reinforced concrete structures down to bedrock or to substantial pilings, but some foundations are steel structures. When the temperature of the air surrounding a foundation changes, the long vertical piers under the bearings are cooled and change length in an amount as described above. Some columns change length more or less than others because some are more exposed to radiant heat from steam pipes than are others, and some are more exposed to changes in the ambient air temperature than others. Some units are so sensitive to the surrounding air temperature that opening a big door in cold weather will cause the vibrations of the turbine-generator to change almost immediately. In a number of cases, the sound of the machine vibrations will change, and will do so in a repeatable manner.

The alignment of the LP turbine rotors relative to each other and to the adjacent turbine or generator rotors is often intentionally adjusted from time to time by turbine engineers, so that at normal operating temperatures, the bearings are fairly evenly loaded as represented by the bearing metal temperatures. It is imperative to retain plant records of what alignment conditions provide the best operating conditions, and to use the latest records of what works best for each unit during the process of aligning the rotors for that unit in subsequent outages.

A series of 750 MW tandem compound GE LST-G units demonstrate the following trends. When cold and when no vacuum is drawn, the LP Turbine Bearing 5 is substantially loaded and Bearing 4 is

completely unloaded. If Bearing 4 is machined on the small size and/or is not set sufficiently high, Journal 4 can contact the top of Bearing 4, causing binding between the top of Bearing 4 and the bottom of Bearing 5 during turning gear operation in cold start-ups. However, when vacuum is drawn and the temperature in the condenser increases, the LP hood changes shape such that Bearing 5 drops and rotates. As the temperatures of the IP Turbine increases, Bearing 4 raises up. When the unit is at normal operating temperature, the bearing metal temperatures of these two bearings evens out showing that the loadings on these two bearings approaches their respective design loads.

For GE tandem-compound trains, it is typical that the largest mismatch between couplings in cold conditions occurs between the last IP Turbine Bearing and the first LP Turbine Bearing. In other words, the first LP Turbine Bearing sees more variation in loading than any other LP Turbine Bearing. The last Turbine Bearing, adjacent to the generator, also sees a variation in loading, but usually not so much variation as the first LP Turbine Bearing experiences.

It is common for the first LP Turbine Bearing to drop, as depicted in the above example, however, there are cases when the LP Hoods distort in such a way as the first LP Turbine bearing is lifted up. This is controlled in part by the area of hood surface below the cone relative to the area of hood surface above the cone, and how the internal bracing is installed.

It is difficult to try to modify the hood structures in such a manner as to reduce the sensitivity of bearing loading to changes of vacuum condition or to condensate temperature. If these changes become concern items on a continuing basis, then the least costly option is to change the last IP Turbine Bearing and/or the first LP

Turbine Bearing from an elliptical bearing to a self-aligning tilting pad bearing, such as a TRI Align-A-Pad® Journal Bearing. Another option that can be added is to use a variable speed circulating water pump to control the condenser cooling water flow rate to maintain the condensate temperature and backpressure to values that are as uniform as possible over the operating range.

Summary of Recommendations:

1. Record characteristics of the wear patterns of the Babbitt, including:

- Non-uniform wear such as hour-glass wear patterns, twisted, end loading, and contact in the top of the bearing.
- Locations where the Babbitt has broken out and where the oil has become burned or plated out on the Babbitt.
- Binding between the top and bottom of adjacent bearings.
- Repeated bearing damage patterns.
- Alignment patterns that work or do not work.
- Abnormal rotor vibration patterns, including changes of phase angles and any appearance of passing through a critical speed while at constant operating rotational speed.
- Condensate temperatures, and particularly, when the condensate is “over-cooled”.

2. Develop correlations that exist for a particular machine between rotor vibration, bearing temperatures, and condenser vacuum and condensate temperatures.

3. Determine from the wear patterns and any other data that is available, the degree to which the bearings drop or raise, and tilt or twist. When solid bore bearings (elliptical bore or circular bore) are used in LP Turbines, it may be necessary during the final

assembly to install the bearings with a “compensatory tilt” in the opposite direction in order to compensate for the tilting action that occurs when vacuum is drawn and when the temperature goes from cold to hot operating temperature conditions.

The larger the turbine, whether 3600 rpm or 1800 rpm, the more important this becomes.

4. When the bearing is located at the desired position, the bearing should be pinched in position to keep it from moving. The pinch should be 0.002 to 0.003 inches. This applies to ALL machines, regardless of manufacturer. The reasoning is that if the rotor goes through a high vibration condition, even for a few seconds, and the bearing is loose (no pinch fit), it is likely that the bearing will move around and change the alignment of the bearing to the journal. TRI has found that in almost all cases, when the bearing moves, it will move to a less desirable position, resulting in an end-loading pattern, or a diagonal wear pattern, or different wear patterns at different times. The pinch fit will help to reduce vibratory amplitudes of the rotor, both synchronous vibrations due to unbalance or sub-synchronous vibrations known as “oil-whip” or “oil whirl”.

5. When it is found that a “compensatory tilt” is required, the starting sequence should be to draw vacuum and then put the unit on turning gear. Drawing vacuum will cause the LP hoods to deflect and will tilt the bearing so that the bearing and journal are closely aligned.

6. For LP Turbine bearings that experience excessive wear or unusual wear patterns as a result of the LP Hood deflection under vacuum conditions, it is recommended to change the bearing to a tilting pad design with self-alignment capability. The TRI Align-A-Pad® Bearing is such a self-aligning bearing. If the

specific bearing loading ($W / L \times D$) is less than 250 psi, a six pad tilting pad bearing may be used, but if the specific bearing loading ($W / L \times D$) exceeds 250 psi, consideration should be given to using a five-pad bearing, as this reduces the “effective loading per pad” on each of the bottom two pads.

7. For the last IP Turbine Bearing (adjacent to the first LP Turbine Bearing), if the vertical movement of the journal is so high that it contacts the top half of the bearing in the cold condition, then TRI recommends that a tilting pad bearing designed for large clearances be used. TRI uses a six-pad Align-A-Pad® Bearing for these applications - with a unique combination of clearances to accommodate the high vertical movement and to be able to control vibration amplitudes under all operating conditions.

8. Where over-cooling of the condensate has occurred with the normal operating conditions for the circulating water pumps, it is appropriate to consider variable speed motors. Under certain circumstances, two-speed motors can be used. In extreme circumstance, turning on or off the circ water pumps may be appropriate to control the cooling of the condensers. Exercising any one of these options may help to optimize the cycle efficiency under various plant conditions and/or ambient conditions.

There is a compromise in establishing the preferred condenser back-pressure: In almost all cases, the colder the cooling water, the lower the back-pressure, and the more MW load that is generated, with all other conditions being the same. However, the

colder the condensate, the more heat that is required to heat the condensate to make the steam for the turbine. The objective should be to cool the condensate no more than is necessary to optimize the efficiency of the cycle. For those units that are operating at maximum firing rate, over-cooling the condensate will actually reduce the MW generated.

9. Many LP Turbine Bearings are marginally stable with the original geometry. If the user does not want to change to self-aligning Tilting pad bearings, which will almost always solve the problems of both (a) non-uniform wear of the babbitt and (b) tendencies to exhibit sub-synchronous vibrations, then there are design upgrades that TRI can implement for most of these bearings that can be expected to improve the wear situation and reduce the sensitivity to synchronous and sub-synchronous vibrations to condenser back-pressure and to condensate temperature conditions. These involve very specific changes to the Babbitt bore geometry that are tailored to each specific circumstance.

10. Please contact TRI for an engineering evaluation of any bearing damage or rotor vibration condition that is related to the aforementioned issues. It is very likely that TRI has a solution for the bearing and rotor vibration issues at hand.

**Contact TRI for consultation
& component supply for your situation.**

TRI product & service info is available at www.turboresearch.com .
We make “house calls” Emergency tel: 610-283-9077.

For more solutions to common problems, visit our “Case Studies” published on our web site:
http://www.turboresearch.com/index_casestudies.asp

This Technical Note was written by Dr. Melbourne F. Giberson, P.E., President of TRI Transmission & Bearing Corp., Turbo Research, Inc. The objectives of Technical Notes are to disseminate information and experience on understanding problems and how to solve them. We attempt to send this Technical Note only to those people for whom the information might be useful. Over the years, many people have asked to be added to the distribution list (see our website). Occasionally, a few individuals inform us that they do not wish to receive the information. Should you desire not to receive future Technical Notes, please advise TRI by info@turboresearch.com or click [visit the removal page](#) on the TRI web site MFG 11/2007